

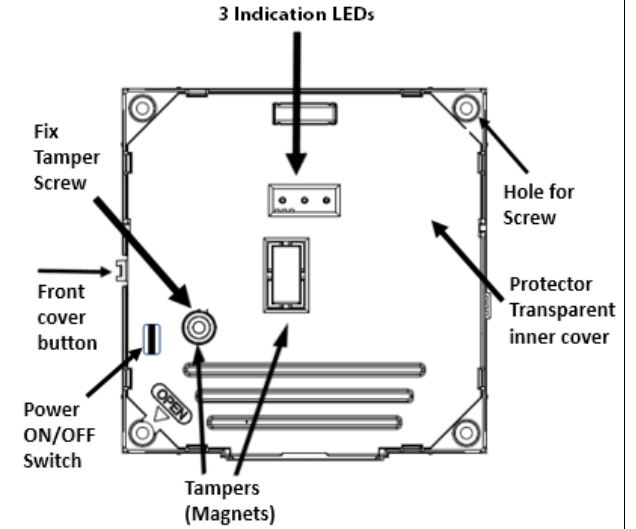

WRPTR
2-Way Wireless CUBE Repeater

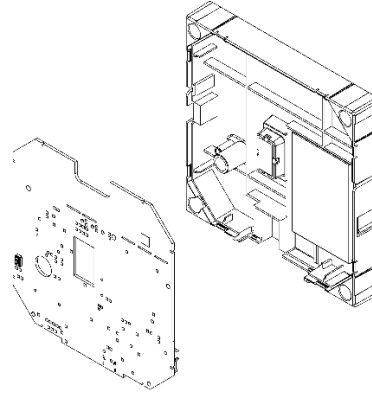
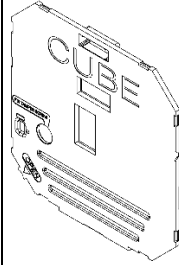

V54554-F108-A100
Document ID: I-200653
(Draft)
Edition: 12.12.2024

4

LEDs

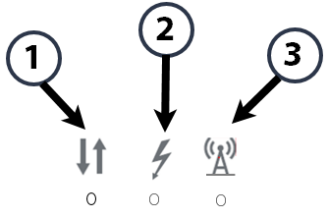

5

Front cover removal tool

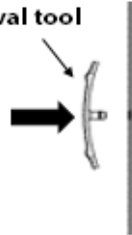

6

- 868MHz
- 1300m in open space
- 3.7V/3Ah Li-Ion Rechargeable
- >48hrs back-up
- *Average <20mA
*Tx <14dBm
- 3.65V
- 130mm x 130mm x 20mm
- 200g (incl. battery)
- 10°C ~ +55°C

7



- Directive: 2014/30/EU (EMC)
- Directive: 2014/35/EU (LVD)
- Directive: 2014/53/EU (RED)
- <http://pcd.vanderbiltindustries.com/doc/wireless>



- EN300 220-2
- EN50131-5-3
- EN301489-3
- EN301489-1
- EN301489-6
- EN301489-17
- EN301489-52
- EN50130-4
- EN50130-5
- EN 62368-1
- EN50131-6
- EN 50131-3
- EN50131-1

Security Grade 2 Environmental Class II
Certification body: KIWA



Vanderbilt
Clonsbaugh Business and Technology Park
Dublin
D17 KV84
Ireland
<https://acresecurity.com>

OVERVIEW

The WRPTR extends the data reception for your alarm system and your connected devices.

The WRPTR receives alarm, status and control messages from the wireless devices and sends these messages to the control panel.

Extends radio communication range of security alarm system by repeating all message types.

- Repeats messages to/from devices that are defined by installer.
- AC Adapter powered with a battery back-up.
- Secure ID 24 Bits encryption.
- Reports devices communication quality upon control panel request.
- Reports Tamper status, AC fail/restore and Battery status.
- Automatic network control.
- LED indications for communication activity and power status.
- Compact and Easy to install.
- Frequency Band 868MHz.

NOTE: The WRPTR is supplied with the battery already connected.

While the WRPTR repeats any Open/Close/Tamper signal, images generated by the PIRCAM are not repeated.

DISCOVERY AND ENROLLMENT PROCESS

Discover the WRPTR from the acre Intrusion control panel:

1. Login as **Full Engineer**.
2. In the acre Intrusion browser, select **Configuration>Wireless>Two Way** and click **Enrol New Device**.
3. Connect the AC power USB to the WRPTR USB connector.
Verify that all 3 LEDs (**Fig. 3, Fig. 4**) are blinking red and green simultaneously for 7 seconds to indicate successful power up. (See **Indication LEDs** in this document)

4. During the discovery process, the following LED sequence occurs:

	LED (Fig. 4)	State	Duration (s)
Power up	Green/Red	Slow Flash	7
Discovery Start	Green	Fast Flash	Continuous
Discovery Complete	Green	Steady -> Slow Flash	1
Discovery Failed*	Red	Slow Flash	Continuous

5. When the discovery process succeeds, the acre Intrusion panel browser displays the **Received, S/N, Status, Type, Version, Signal**, and **Receiver** information.
6. Click **Add** to display the **Repeater Configuration** page.
7. Identify the WRPTR by entering a name in the Description field (maximum 16 characters) and select Standalone from the Standalone or Keypad drop-down.
8. Click **Save**.
The WRPTR is now enrolled on your acre Intrusion system.

Discover and enroll the WRPTR from the keypad:

1. Login as **Full Engineer**.
2. Select **WIRELESS > REPEATERS > ADD**.
The keypad displays the **ADD** screen with a flashing **ENROL DEVICE** message.
3. Connect the AC power USB to the WRPTR USB connector.
When the discovery process succeeds, the keypad displays the **FOUND REPEATER** screen with the unique Repeater ID and the Signal Level.
4. Click **Enter** to confirm and to display the **ADD** screen.
5. (Optional) Enter up to 16 characters in the **Description** field to help identify the location of the WRPTR.
6. Click **Enter** to confirm and to display the **REPEATER TYP/LOC** screen.
7. Select **Standalone** in the **REPEATER TYP/LOC** drop-down and click **Enter**.
8. The keypad briefly displays an **UPDATED** message and returns to the **REPEATERS** screen.
The WRPTR is now enrolled on your acre Intrusion system.

Note: Initialization delay time = up to 40 seconds.

Repeat initialization time = up to 1 second.

*DISCOVERY FAILED

1. Switch off the device using the internal power switch (**Fig. 3**).
2. Plug into mains power.
3. Check repeater details and repeat steps 3-5.

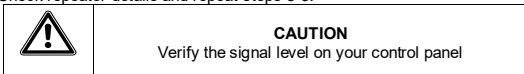

Indication LEDs

See **Fig. 4**

POWER UP. The three LEDs flash red-green for 7 seconds.

Fig.4, item 1

COM.DEV. – Indicates the communication between Control Panel and the Wireless Devices, blinks green Led every repeated message from a device for 1 sec.

Fig.4, item 2

POWER – Indicates the power is ON or OFF.

- Flashing green indicates – AC power is connected, and battery is fully charged.
- Flashing red & green – AC power is connected, and the battery is charging.
- Flashing red – AC failed

Fig.4, item 3

COM.AIC – indicates the communication between the Repeater and control panel, blinking green led indicates device is enrolled and communicating with control panel.

NOTE: AC power failure displays on the Wireless Status page within 20 seconds after power AC failure occurs.

Removing the front cover

See **Fig.3, Fig.5**.

Power ON/OFF Switch – used to shut down the repeater when AC fails or disconnected.

1. Disconnect the AC power.
2. Ensure the POWER LED is flashing red, wait 10 seconds.
3. Press and hold the Switch button for a few seconds.

The 3 LEDs (**Fig.4**) light red for 1 second and then turn off to avoid battery disconnection.

To turn the repeater power ON connect the AC power back.

Front cover button – press the button and hold to remove the front cover off the base (see **Fig.3**).

BATTERY REPLACEMENT

The battery is located below the PCB board

1. Remove the front cover of the WRPTR.
2. Remove the protector transparent inner cover (**Fig. 2**) using the opening located at the left corner.
3. Remove the PCB board.
4. Disconnect the battery connector.
5. Replace the battery.

